

Designer's
NOTEBOOK
CORNERS AND RETURNS



Corners And Returns Create Design Challenges — Article VII

PCI's Architectural Precast Concrete Services Committee explains that designing corner details requires special attention to optimize appearance, jointing and economy

Each project requires special attention to the design and detailing of its corners to create the optimum appearance, jointing and economy. For this reason, corner detailing should be decided early. Economy results when the building elevations are designed from the corners inward, using typical panels, thus avoiding specially sized end or corner pieces.

All edges of precast concrete units should be designed with a reasonable radius or chamfer, rather than leaving sharp corners. This is particularly important where the panels are close to pedestrian or vehicular traffic. When the edge is sharp, only fine aggregate collects in these locations, and this weakens the edge. Voids also occur due to the interference of larger aggregate. Sharp corners chip easily, both during handling and during service on the finished building. For typical edge details, see Fig. 1.

The size of the edge's radius should be discussed with the precaster. Determining the optimum size depends on the selected aggregate size, mold materials and production techniques. A 3/16- or 5/16-inch minimum radius should be satisfactory for smooth concrete or a light textured surface. A 1/4- or 5/16-inch rounded edge should be satisfactory for an exposed-aggregate finish with a maximum aggregate size of 1/2 inch. Above that aggregate size, the edge must be progressively more rounded.

Miters Must Be Cut Off

Concrete at mitered corners cannot be cast to a sharp 45-degree point because of the size of the aggregates. Therefore, this edge must have a cut-off or quirk. Fig. 2 shows the recommended size of the quirk return for different panel joint sizes. The size of the quirk return should never be less than 3/4 inch nor less than 1.5 times the maximum size of the aggregate used in the concrete mix. Normally a 3/4- to 1-1/2-inch quirk will read as a well-defined vertical edge on the corner of the building.

Returns In Relation To Finishes

The precast concrete unit's finish should be considered before its shape is finalized. Many finishes cannot be achieved with equal visual quality on all faces of the unit.

The reasons encompass factors such as mix proportions, variable depths (and pressures) of concrete, and small differences in consolidation techniques, particularly in the case of intricate shapes with complex flow of concrete. The effect of gravity during consolidation forces the large aggregates to the bottom and the smaller aggregates, plus the sand and cement content, upwards. Consequently, the down-face in the mold nearly always will be more uniform and denser than the returns or upper radius of curved panels.

Consolidation of concrete results in a more or less uniform orientation of the aggregate, with the flat, long portion horizontal to the bottom of the mold. On returns and on the upper radius of curved panels, the sharp angular points of the aggregate will show upon exposure. This can give returns greater than 12 inches a finished texture distinctly different from that of the down-face, as shown in Fig. 3.

Corner treatments, such as 12-inch corner returns, usually influence all corner pieces for the project. See Fig. 4 for typical corner and return details.

With deep returns, a more uniform finish is obtained with a retarded, exposed-aggregate finish. When an exposed-aggregate finish is specified, concrete mixes with aggregates that are reasonably

Fig. 1 Typical Edge Details

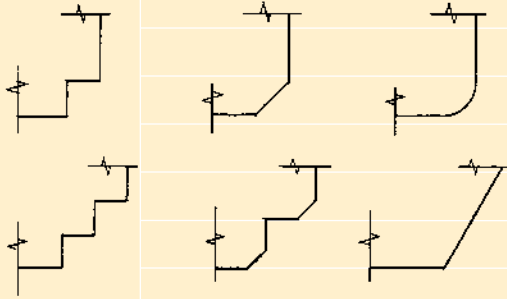
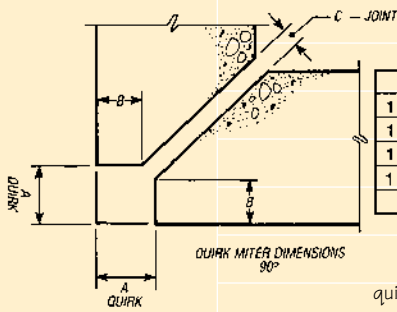

Fig. 2 Quirk Miter Dimensions



A	B	C	A	B	C
1 1/8	3/4	1/2	1 1/4	3/4	3/4
1 1/4	7/8	1/2	1 1/2	1	3/4
1 1/2	1 1/8	1/2	1 3/4	1 1/4	3/4
1 3/4	1 3/8	1/2	2	1 1/2	3/4
2	1 5/8	1/2	1 1/2	1 3/16	1
			1 3/4	1 1/16	1
			2	1 5/16	1

quirk miter: A corner formed by two chamfered panels to eliminate sharp corners and ease alignment

Fig. 3 Exposure Variances Caused By Aggregate

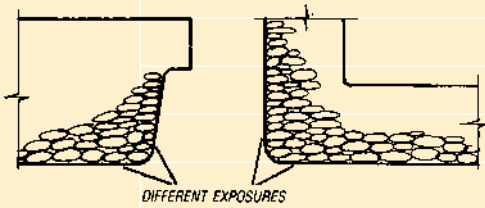
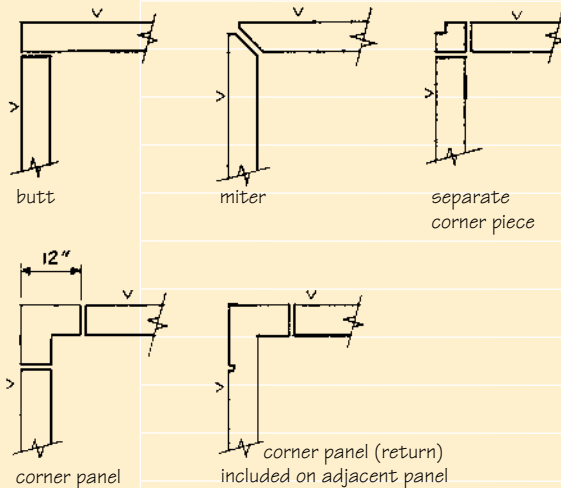

Fig. 4 Typical Corner And Return Details



return: A projection that is 90 deg. to or splayed from main face or plane of view

Fig. 5 Alternate Casting Approaches

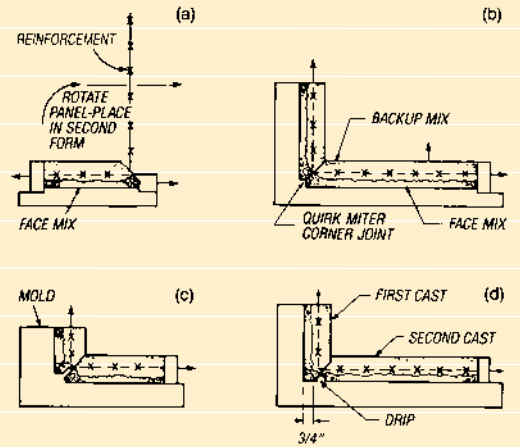

Fig. 6 Preassembled Corner



Fig. 7 Column Covers With Returns

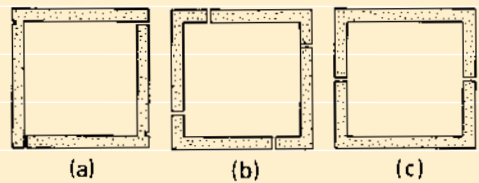
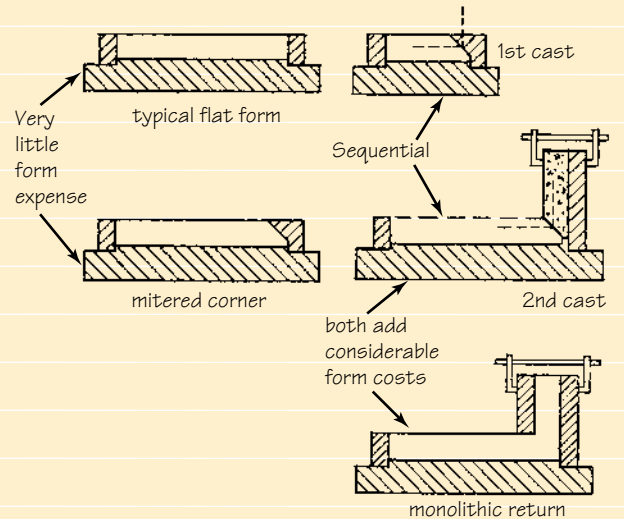

Fig. 8 Corner - Return Molds



Two Stage Or Sequential Returns

spherical or cubical should be chosen to minimize differences between down-faces and returns. For panels with large returns, or other situations where variations in appearance must be minimized, the two-stage or sequential production technique should be used, if feasible. Otherwise, concrete mixes should have a continuous graded coarse aggregate and ASTM C33 sand. Exposure of aggregates should be medium to deep with minimal color differences between mix ingredients.

Panels with large or steep returns (such as channel column covers and some spandrels) may be cast in separate pieces in order to achieve matching, high-quality finishes on all exposed faces and then joined with dry joints, as shown in Fig. 5. This method of casting enables all faces to be cast face-down with the same aggregate orientation and concrete density using conventional precast concrete forming methods. Also, a combination of face mix and backup mix can be used, rather than 100 percent face mix.

If this is the indicated production method, attention should be paid to suitable corner details and reinforcement at the dry joints. Although the dry joint may not show with certain mixes and textures, a groove or quirk should be used to mask the joint. Where desired, the joint can be recessed deeply enough to allow installation of a small backer rod and placement of a 1/4-inch bead of joint sealant, as shown in Fig. 5c.

Corner Panels With Returns

An alternate to mitering is the use of a separate corner panel to add interest to the façade, see Fig. 4. Special corner pieces can be cast by using modified standard unit molds, which is part of the master mold concept. If the size of the project or the available time constraints warrant multiple molds, a separate corner mold is recommended.

Corner molds are generally small and simple. On a high-rise building, the cost of a small corner mold and the handling of an extra piece may offset the modification costs of the master mold and/or be justified by the additional flexibility in erection tolerances. Separate corners also may be advantageous in providing similar orientation of corner surfaces for matching finishes. Or the corner pieces may economically be designed and produced as part of one of the adjacent typical panels.

Some precasters occasionally choose to preassemble corner pieces at the plant. This procedure can be both efficient (eliminating alignment problems) and economical. Fig. 6 shows an example of such an assembly done in a jig in the precaster's yard.

Fig. 7 displays some of the various shapes of column covers that can be made with butt or mitered joints, including (a) two L-shaped units, (b) four L-shaped units, and (c) two U-shaped units. There are, of course, many other combinations that can be used to accommodate isolated columns, corner columns and columns in walls.

Sequential and monolithic corner (return) molds are both more costly than mitered molds, see Fig. 8. A separate corner panel often requires an additional mold.

A Design Approach To Corners

Donald J. Benz, senior associate/technical resources manager for Thompson, Ventulett, Stainback & Associates in Atlanta, presents his tips for creating corners and returns in precast concrete

Articulating Thickness At The Corner



Fig. 1: The heavily rusticated panels used on 1335 Windward Concourse in Atlanta are thickened flat panels with exaggerated 3-inch quirks at the corners to create a return back into the interior of the building, giving it a perceived dimension.

Architectural precast concrete has been a mainstay in the palette of building design materials used at Thompson, Ventulett, Stainback & Associates for the past 30 years. During this period, several consistent approaches to detailing corners have evolved. How the precast is being used and the type of panel that is turning the corner determines how the building corners and major component edges will be designed.

Flat panels, used either to visually define the dimensioned mass of building-block elements or to create flat or curvilinear planar surfaces, are treated differently than panels with heavily articulated horizontal treatment using deep relief reveals or profiles. Visual focus at the corners often is part of a design approach where the wall plane is stopped or interrupted at the building corner or the corner is emphasized to define the building form.

Quirk miter corners, cast channel shapes with returns and two-stage precasting all have achieved the desired result, often with modifications contributed by the precaster that benefit both the finished design and the budget.

Providing a visible expression of the building panel or unit width as it turns the corner gives substance and thickness definition to the material. A deeper quirk return, in the range of 3 inches, offers an economical way to create a discernable thickness in the material as it turns the corner. This is shown in Fig. 1. A similar exaggerated quirk is used in Fig. 3 for both a return dimension and emphasis on the corner.

When the panel thickness itself is to be expressed, a butt joint around the corner at the back of the panel is sufficient without a return. In Figs. 2 and 3, shallow and deep returns, respectively, are used to indicate a building-block element thickness greater than the actual depth of the precast panel.



Fig. 2: On Chicago's McCormick Place Expansion project, one-piece channel-shaped covers with relatively shallow returns were used to imply a thickness somewhat more than the actual panel thickness. In this case, well-executed "sharp" corners in the casting add to the solid appearance.



Fig. 3: Two-stage cast covers with deep returns were used for the solid-block treatments of piers at the Merrill Lynch Campus in Denver. The two-stage precasting allows a unique cast-in surface texture to be carried around the corners of the blocks to a much deeper dimension. Minimal corner dry joints without quirks complete the appearance of a solid unit.

The Wall Plane Turning The Corner



Fig. 4: This flat wall plane on the 55 Farmington building in Hartford, Conn., changes direction without corner articulation by using a shallow angle return for single casting and placing the joints at the back angles where they are de-emphasized. The shallow corner angle allows a solid cast edge.

When the wall surface is treated as a planar surface, smooth or articulated, the goal usually is to make the transition around the corner as smooth and continuous as possible. This often involves moving the joint from the prominence of a corner location, especially with smooth panel faces. Figs. 4, 5 and 6 illustrate situations where a solid-appearing corner is preferred. This allows the smooth surface to carry around the corner uninterrupted and without calling attention to the corner.



Fig. 5: The returns on these column enclosures at the McCormick Place Expansion project in Chicago aren't intended to imply a material thickness of panels or blocks but to provide a planar wrap of the surfaces forming the corner. The joint is located at the pier's center to provide a linear continuation of the element above the pier.

Fig. 6: (left) In the smaller-scale detail provided at the ADP Building, Atlanta, a two-stage casting and dry-joint corner provide an abrupt but continuous return of the plane of the curvilinear sweep to the building face.

On the other hand, horizontal spandrel panels with deep rustication, or a contained sculptured profile, such as that shown in Fig. 7, require a miter to carry that panel profile accurately around the corner.

Fig. 7: The minimal quirk miter corner in the spandrel panels at the Metropolitan Life Building in Atlanta provides an uninterrupted planer return of the profiled wall-panel surface without corner articulation. A two-stage casting at the cornice provides a similar planer wrap around the top. These sharp corners at the top emphasize the building corner's larger-scale articulation. Details closer to pedestrians use the quirk corner for more finished detail.



Defining The Corners

Fig. 9: Separate corner pieces are used at BellSouth Campanile in Atlanta to interrupt the wall plane at the corner, emphasizing the corners by vertically articulating the larger multistory lobby space at the base from the typical floors above.



Special corner treatment often is used to emphasize the corner to define the intersection of the wall planes with detail as shown in Figs. 8 and 9. The degree of detail complexity and richness, which relates to budget, determines the casting technique.

Fig. 10 represents a stronger corner treatment. Solid precast corner elements are used to define the starting and stopping of the wall plane materials of glass curtain wall and precast wall panels. At the macro scale, these solid pieces have their corners articulated with quirks to add visual interest and to facilitate corner quality control.



Fig. 8: The depth and shadowing of the façade on the Carrillon Building's parking structure in Charlotte, N.C., is continued in the detailing of the pier corners by using deep quirk miters to accent the corners with the shadow created by the larger quirk.



Fig. 10: Solid precast vertical pieces are used on the Glenridge Highlands One project in Atlanta to define the corners and the transitions from curtain wall to precast at the corners. Originally planned as returns and channel spandrel covers, they were cast solid at the precaster's suggestion for economy and detailing simplification.

The Future

The treatment of building corners, as well as smaller-scale, building-component corners, is critical to the final perception of the architecture. The corners are focal points where wall planes and materials change or continue. The corners outline and define the form of the building and the corners are where the light falling on the surfaces of the façades transitions dramatically. Use of architectural precast concrete in corners will continue to challenge existing and evolving precasting techniques to capitalize on design excellence and economic constructibility.

— Donald J. Benz, senior associate/technical resources manager,
Thompson, Ventulett, Stainback & Associates, Atlanta